



Creating a Green World



Product Installation Guide

HYDROCYCLONE (Installation)



Step 1: Open the carton as hydrocyclone packing is horizontal.



Step 2: Gently take out the collector tank from the carton.



Step 3: Open the Clamp fixed onto the collector tank.



Step 4: Open separate box having collector Tank cap, Place the cap properly on collector tank and tighten the clamp.



Step 5: Take out the Ball valve that is in one separate box, install on collector tank cap as shown in above picture.



Step 6: Take out top Hydro cyclone assembly and install on collector tank by matching the hole, now put Bolts into the hole.



Step 7: Initially tighten the nut on each bolt manually, for further tightening, use. proper size spanner.



Step 8: Flanged gasket placed in between the outlet of hydrocyclone and flanged Elbow and match the holes for properly placed bolts.



Step 9: Now tighten the nut with washers, all parts of hydrocyclone assembly from carton is ready for installation on line.

PP HEAD UNIT (Flange Welded)

2"

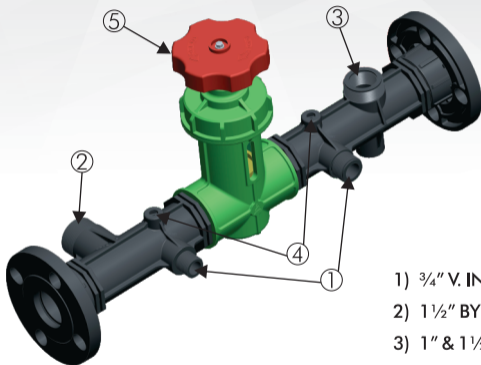

| AIPL Code | Venturi Port |
|-----------|--------------|
| 17020016 | 3/4" |
| 17020024 | 1" |

- 1) 3/4" V. INJ / 1" V. INJ PORT.
- 2) 1 1/2" BY PASS.
- 3) 1" & 1 1/2" AIRVENT PORT.
- 4) BOTH SIDE PRESSURE GAUGE PORT.
- 5) 2" THROTTLE VALVE IN MIDDLE.

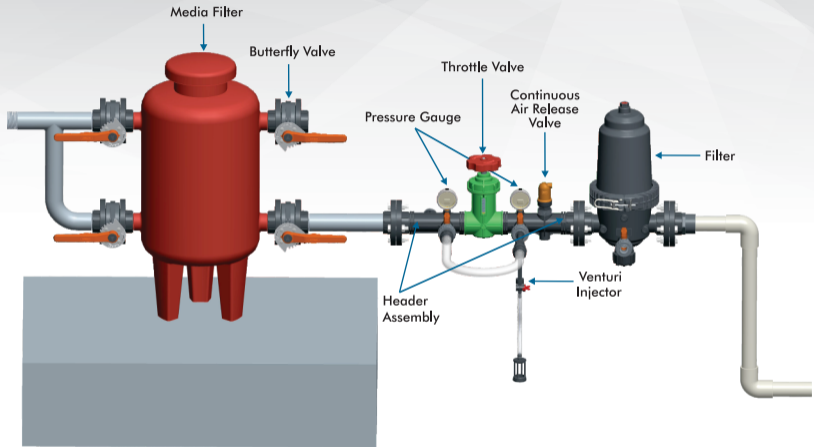

PP HEAD UNIT(Flange Welded)

2" x 2"

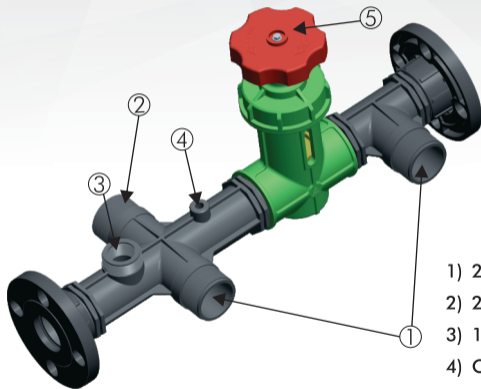

| AIPL Code | Venturi Port |
|-----------|--------------|
| 17020025 | 2" |
| 17020026 | 1½" |

- 1) 2" V. INJ PORT / 1½" V. INJ PORT
- 2) 2" BY PASS / 1½" BY PASS
- 3) 1" & 1½" AIRVENT PORT.
- 4) ONE SIDE PRESSURE GAUGE PORT.
- 5) 2" THROTTLE VALVE IN MIDDLE.

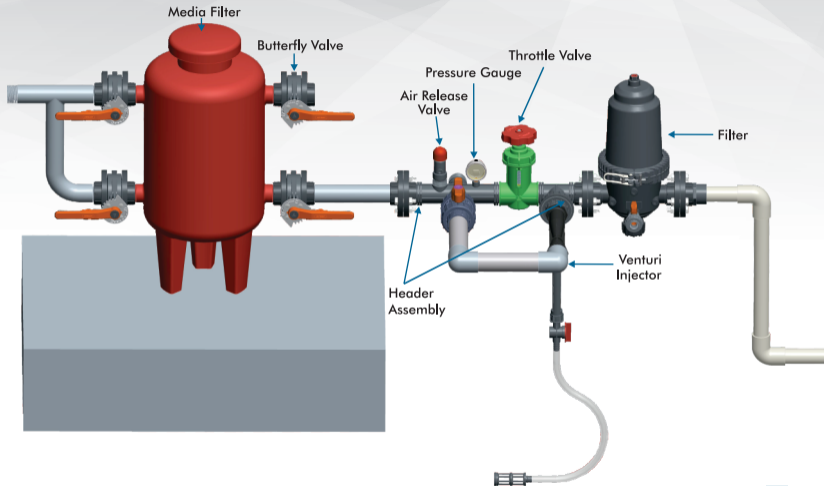

PP HEAD UNIT (Flange / Female Threaded)

2"

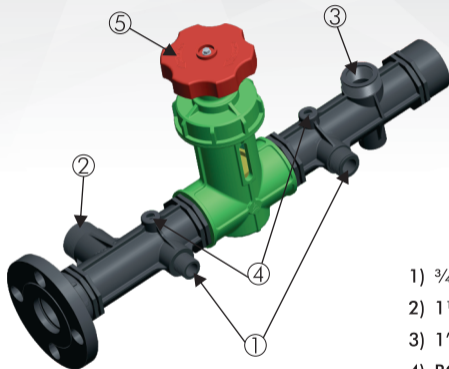

| AIPL Code | Venturi Port |
|-----------|--------------|
| 17020018 | 3/4" |
| 17020028 | 1" |

- 1) 3/4" V. INJ / 1" V. INJ PORT.
- 2) 1 1/2" BY PASS.
- 3) 1" & 1 1/2" AIRVENT PORT.
- 4) BOTH SIDE PRESSURE GAUGE PORT.
- 5) 2" THROTTLE VALVE IN MIDDLE.

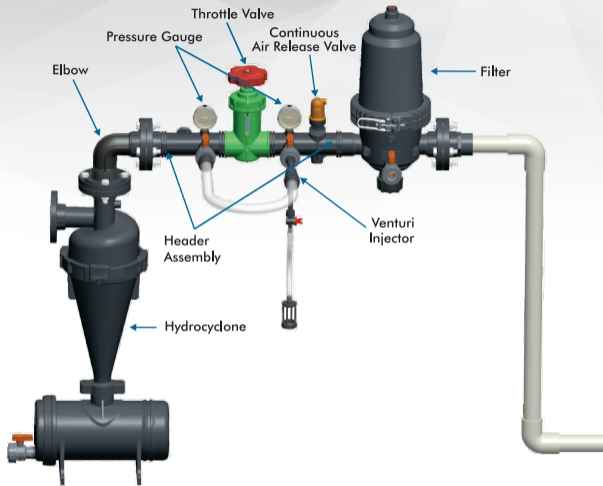

PP HEAD UNIT (Male / Female Threaded)

2"

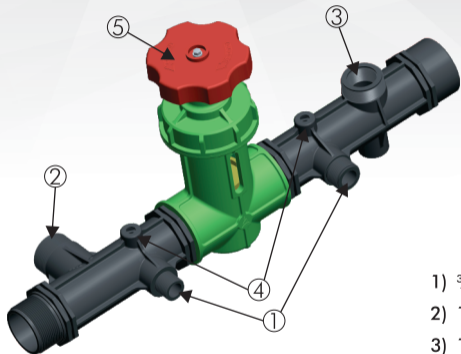

| AIPL Code | Venturi Port |
|-----------|--------------|
| 17020020 | 3/4" |
| 17020027 | 1" |

- 1) 3/4" V. INJ / 1" V. INJ PORT.
- 2) 1 1/2" BY PASS.
- 3) 1" & 1 1/2" AIRVENT PORT.
- 4) BOTH SIDE PRESSURE GAUGE PORT.
- 5) 2" THROTTLE VALVE IN MIDDLE.

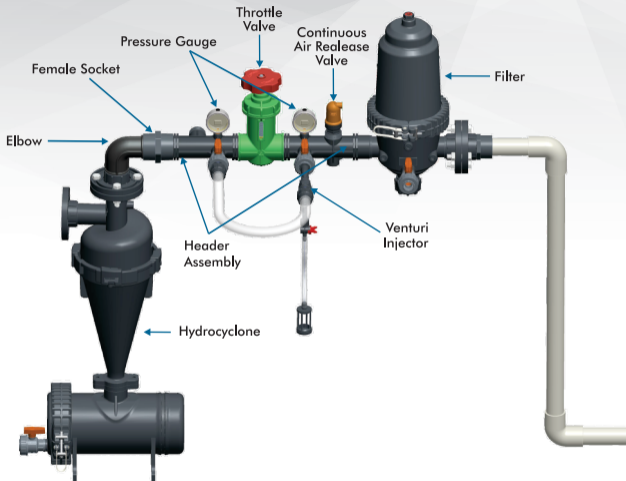

PPGF HEAD UNIT(Flange threaded)

2" x 2"

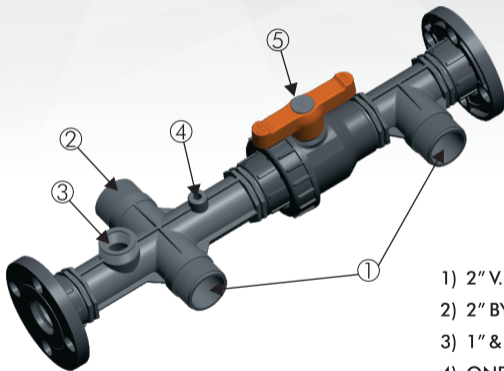

| AIPL Code | Venturi Port |
|-----------|--------------|
| 17030030 | 1½" |
| 17030029 | 2" |

- 1) 2" V. INJ PORT / 1½" V. INJ PORT.
- 2) 2" BY PASS / 1½" BY PASS.
- 3) 1" & 1½" AIRVENT PORT.
- 4) ONE SIDE PRESSURE GAUGE PORT.
- 5) 2" S.U PVC BALL VALVE IN MIDDLE.

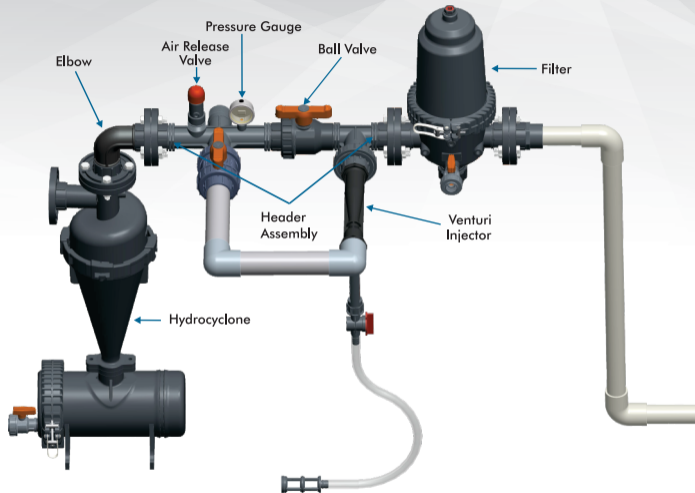

PPGF HEAD UNIT (Flange threaded)

2"

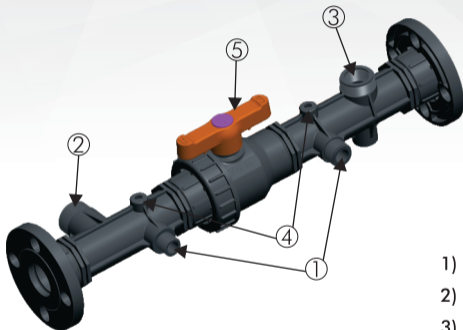

| AIPL Code | Venturi Port |
|-----------|--------------|
| 17030007 | 3/4" |
| 17030009 | 1" |

- 1) 3/4" V. INJ / 1" V. INJ PORT
- 2) 1 1/2" BY PASS.
- 3) 1" & 1 1/2" AIRVENT PORT.
- 4) BOTH SIDE PRESSURE GAUGE PORT.
- 5) 2" S.U PVC BALL VALVE IN MIDDLE.

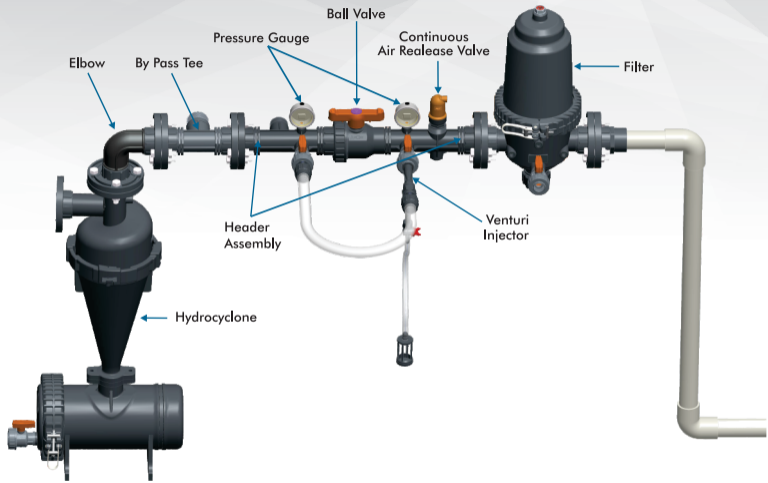

PP SHORT HEAD UNIT (Flange Welded)

2½"

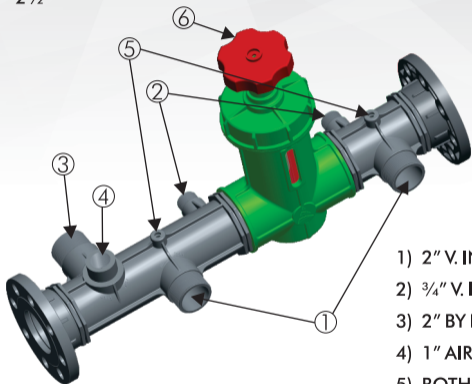

| AIPL Code | Venturi Port |
|-----------|--------------|
| 17050005 | 2" & ¾" |
| 17050006 | 2" & 1" |
| 17050007 | 1½" & ¾" |
| 17050008 | 1½" & 1" |

- 1) 2" V. INJ / 1½" V. INJ PORT.
- 2) ¾" V. INJ / 1" V. INJ PORT
- 3) 2" BY PASS / 1½" BY PASS.
- 4) 1" AIRVENT PORT / 1½" AIRVENT PORT.
- 5) BOTH SIDE PRESSURE GAUGE PORT.
- 6) 2½" THROTTLE VALVE IN MIDDLE.

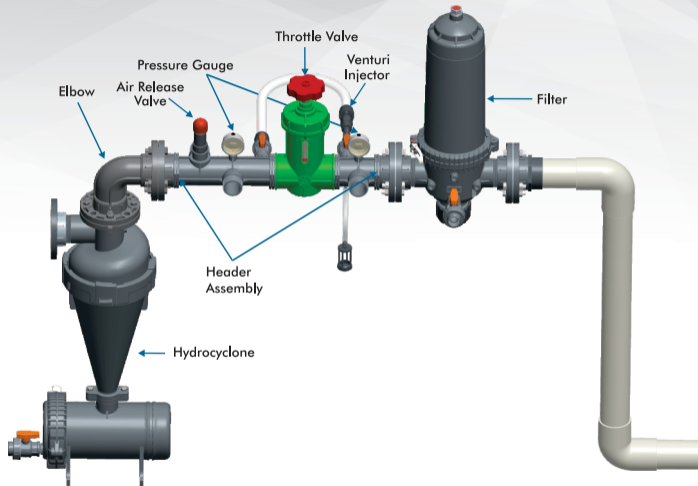

PP SHORT HEAD UNIT (Flange / Female Threaded)

2½"

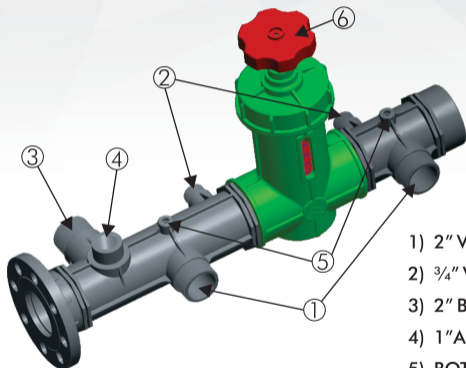

| AIPL Code | Venturi Port |
|-----------|--------------|
| 17050001 | 2" & ¾" |
| 17050002 | 2" & 1" |
| 17050003 | 1½" & ¾" |
| 17050004 | 1½" & 1" |

- 1) 2" V. INJ / 1 ½" V. INJ PORT.
- 2) ¾" V. INJ / 1" V. INJ PORT.
- 3) 2" BY PASS / 1 ½" BY PASS
- 4) 1" AIRVENT PORT / 1 ½" AIRVENT PORT.
- 5) BOTH SIDE PRESSURE GAUGE PORT.
- 6) 2 ½" THROTTLE VALVE IN MIDDLE.

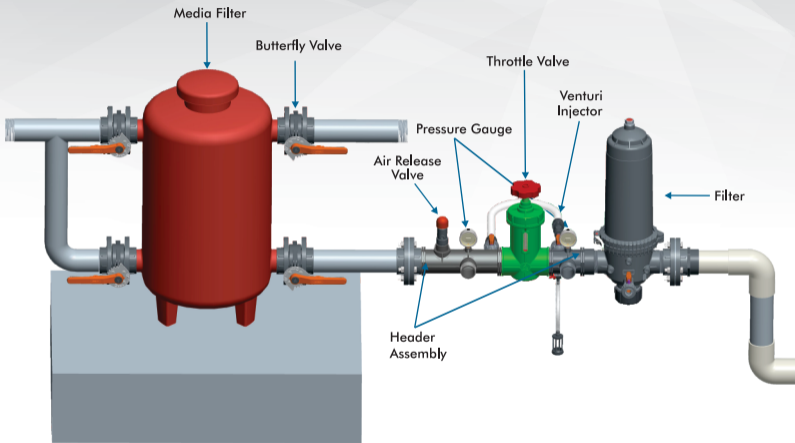

PP SHORT HEAD UNIT (Male / Female Threaded)

2½"

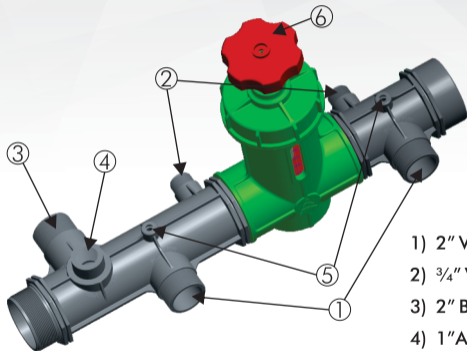

| AIPL Code | Venturi Port |
|-----------|--------------|
| 17050009 | 2" & ¾" |
| 17050010 | 2" & 1" |
| 17050011 | 1½" & ¾" |
| 17050012 | 1½" & 1" |

- 1) 2" V. INJ / 1 ½" V. INJ PORT.
- 2) ¾" V. INJ / 1" V. INJ PORT.
- 3) 2" BY PASS / 1 ½" BY PASS
- 4) 1" AIRVENT PORT / 1 ½" AIRVENT PORT.
- 5) BOTH SIDE PRESSURE GAUGE PORT.
- 6) 2 ½" THROTTLE VALVE IN MIDDLE.

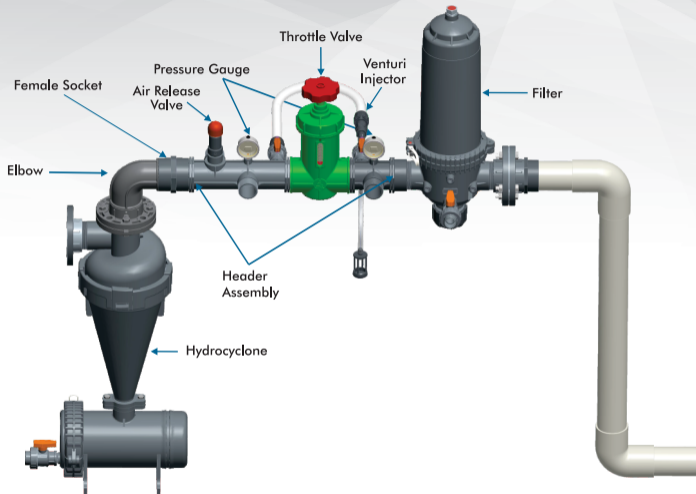

PPGF SHORT HEAD UNIT (Flange threaded)

2½"

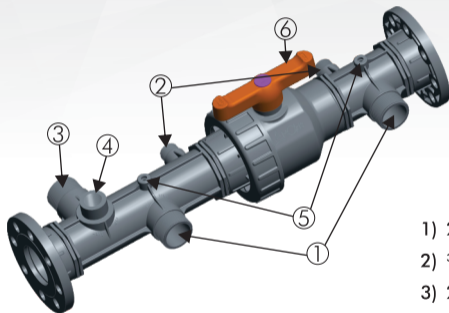

| AIPL Code | Venturi Port |
|-----------|--------------|
| 17060039 | 2" & ¾" |
| 17060040 | 2" & 1" |
| 17060041 | 1½" & ¾" |
| 17060042 | 1½" & ¾" |

- 1) 2" V. INJ / 1½" V. INJ PORT.
- 2) ¾" V. INJ / 1" V. INJ PORT.
- 3) 2" BY PASS / 1½" BY PASS
- 4) 1" AIRVENT PORT / 1½" AIRVENT PORT
- 5) BOTH SIDE PRESSURE GAUGE PORT.
- 6) 2½" S.U PVC BALL VALVE IN MIDDLE.

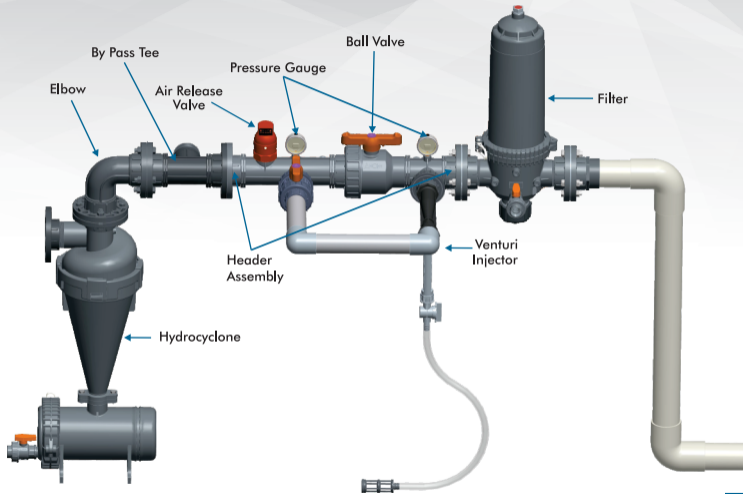

PPGF HEAD UNIT (Flange threaded)

2½"

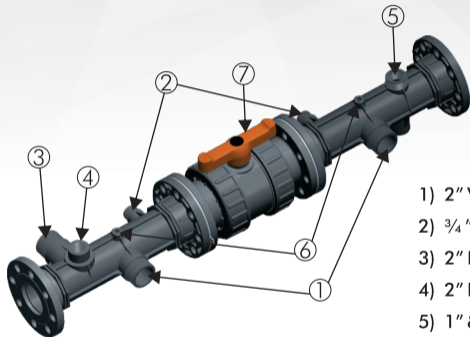

| AIPL Code | Venturi Port |
|-----------|--------------|
| 17060021 | ¾" & 2" |
| 17060043 | 2" & 1" |
| 17060044 | 1½" & ¾" |
| 17060045 | 1½" & 1" |

- 1) 2" V. INJ / 1½" V. INJ PORT.
- 2) ¾" V. INJ / 1" V. INJ PORT.
- 3) 2" BY PASS / 1½" BY PASS
- 4) 2" PRV PORT
- 5) 1" & 1½" AIRVENT PORT.
- 6) BOTH SIDE PRESSURE GAUGE PORT.
- 7) 2½" D.U. FLANGED PVC BALL VALVE IN MIDDLE

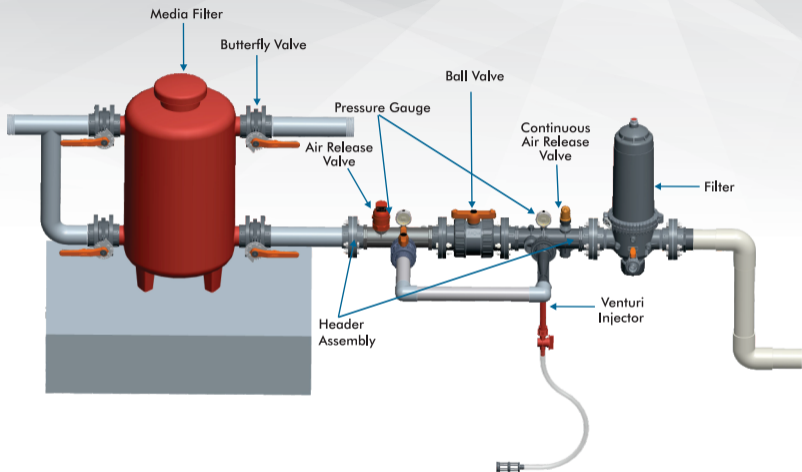

PPGF HEAD UNIT (Flange Threaded)

2½"

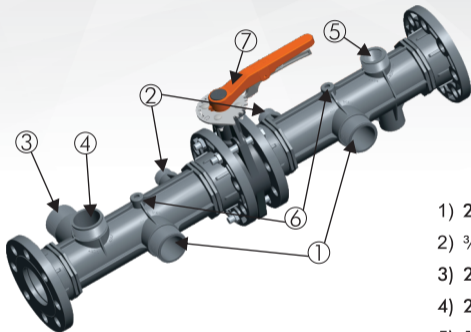

| AIPL Code | Venturi Port |
|-----------|--------------|
| 17060046 | ¾" & 2" |
| 17060047 | 2" & 1" |
| 17060048 | 1½" & ¾" |
| 17060049 | 1½" & 1" |

- 1) 2" V. INJ / 1½" V. INJ PORT.
- 2) ¾" V. INJ / 1" V. INJ PORT
- 3) 2" BY PASS / 1½" BY PASS
- 4) 2" PRV PORT
- 5) 1" & 1½" AIRVENT PORT.
- 6) BOTH SIDE PRESSURE GAUGE PORT.
- 7) 2½" BUTTERFLY VALVE IN MIDDLE.

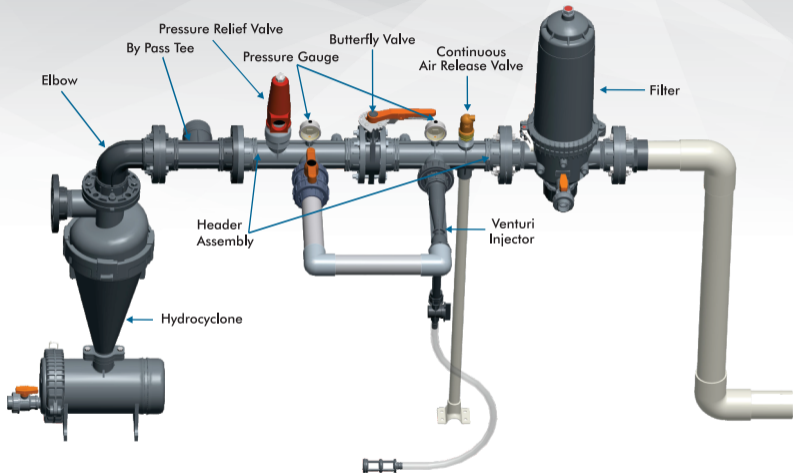

PP SHORT HEAD UNIT (Flange Welded)

3"

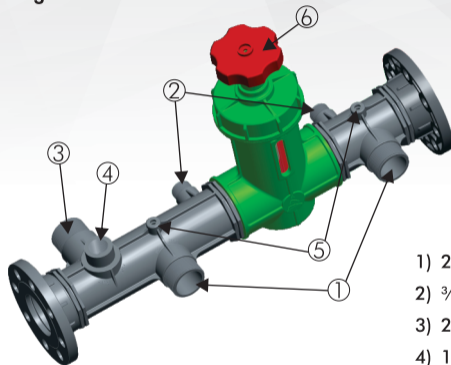

| AIPL Code | Venturi Port |
|-----------|---------------|
| 17080030 | 3/4" & 2" |
| 17080038 | 2" & 1" |
| 17080039 | 1 1/2" & 3/4" |
| 17080040 | 1 1/2" & 1" |

- 1) 2" V. INJ / 1 1/2" V. INJ PORT.
- 2) 3/4" V. INJ / 1" V. INJ PORT
- 3) 2" BY PASS / 1 1/2" BY PASS.
- 4) 1" AIRVENT PORT / 1 1/2" AIRVENT PORT.
- 5) BOTH SIDE PRESSURE GAUGE PORT.
- 6) 3" THROTTLE VALVE IN MIDDLE.

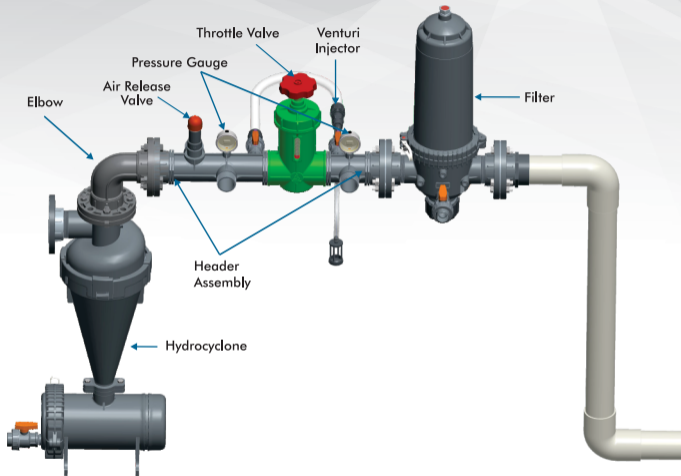

PP SHORT HEAD UNIT (Flange / Female Threaded)

3"

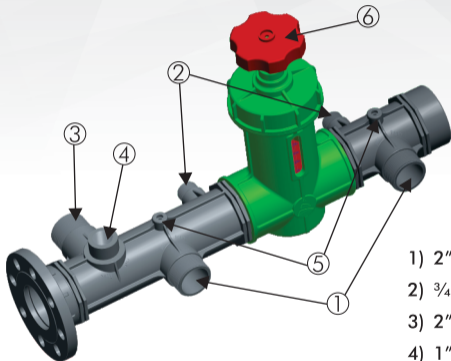

| AIPL Code | Venturi Port |
|-----------|---------------|
| 17080031 | 3/4" & 2" |
| 17080032 | 2" & 1" |
| 17080033 | 1 1/2" & 3/4" |
| 17080034 | 1 1/2" & 1" |

- 1) 2" V. INJ / 1 1/2" V. INJ PORT.
- 2) 3/4" V. INJ / 1" V. INJ PORT
- 3) 2" BY PASS / 1 1/2" BY PASS.
- 4) 1" AIRVENT PORT / 1 1/2" AIRVENT PORT.
- 5) BOTH SIDE PRESSURE GAUGE PORT.
- 6) 3" THROTTLE VALVE IN MIDDLE.

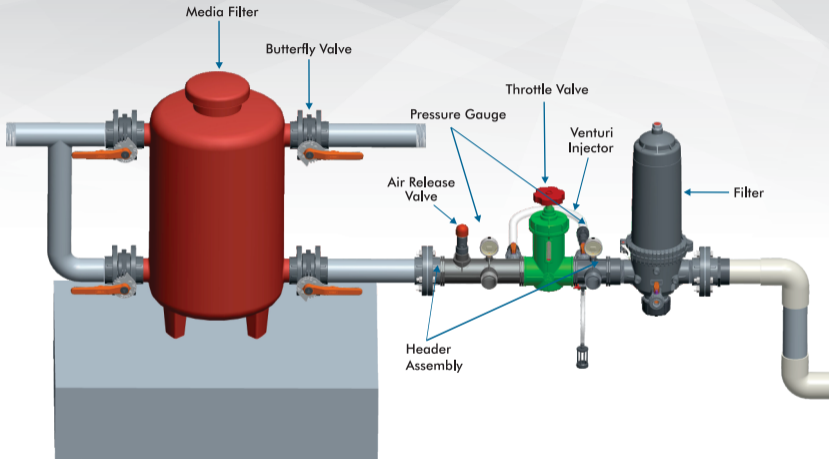

PP SHORT HEAD UNIT (Male / Female Threaded)

3"

| AIPL Code | Venturi Port |
|-----------|---------------|
| 17080026 | 3/4" & 2" |
| 17080035 | 2" & 1" |
| 17080036 | 1 1/2" & 3/4" |
| 17080037 | 1 1/2" & 1" |

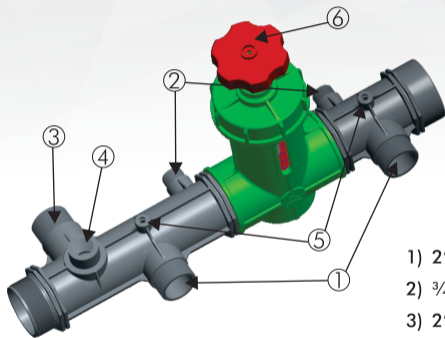

- 1) 2" V. INJ / 1 1/2" V. INJ PORT.
- 2) 3/4" V. INJ / 1" V. INJ PORT
- 3) 2" BY PASS / 1 1/2" BY PASS.
- 4) 1" AIRVENT PORT / 1 1/2" AIRVENT PORT.
- 5) BOTH SIDE PRESSURE GAUGE PORT.
- 6) 3" THROTTLE VALVE IN MIDDLE.

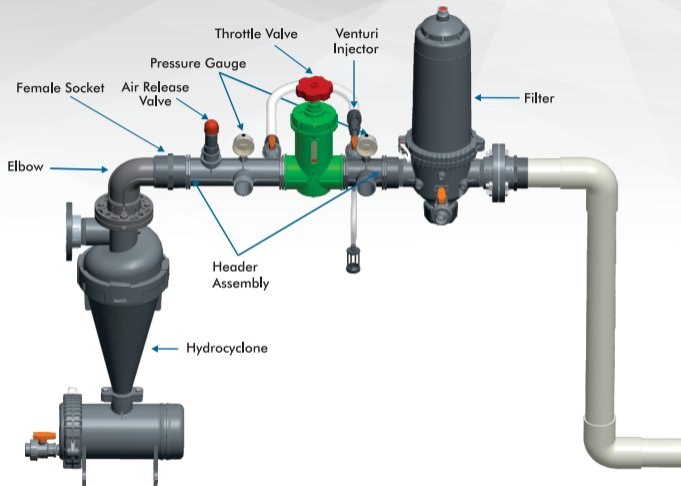

PPGF SHORT HEAD UNIT (Flange Threaded)

3"

| AIPL Code | Venturi Port |
|-----------|--------------|
| 17090079 | 1½" & 1" |
| 17090080 | 1½" & ¾" |
| 17090081 | 2" & 1" |
| 17090082 | ¾" & 2" |

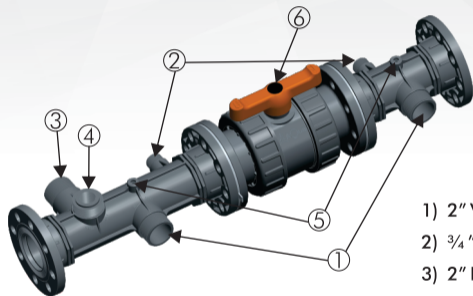

- 1) 2" V. INJ / 1½" V. INJ PORT.
- 2) ¾" V. INJ / 1" V. INJ PORT
- 3) 2" BY PASS / 1½" BY PASS.
- 4) 1" AIRVENT PORT / 1½" AIRVENT PORT.
- 5) BOTH SIDE PRESSURE GAUGE PORT.
- 6) 3" D.U. FLANGED PVC BALL VALVE IN MIDDLE

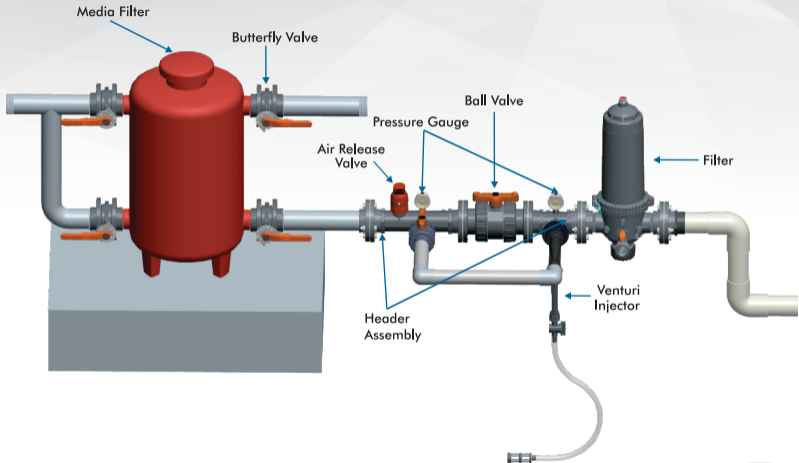

PPGF SHORT HEAD UNIT (Flange Threaded)

3"

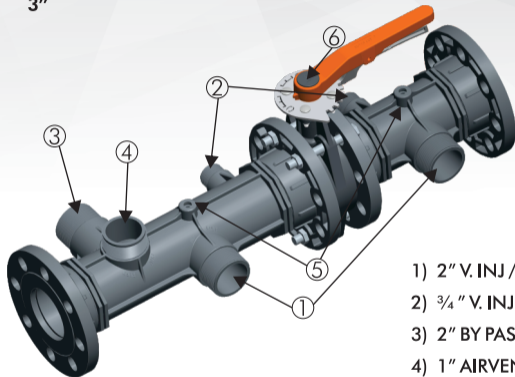

| AIPL Code | Venturi Port |
|-----------|---------------|
| 17090071 | 3/4" & 2" |
| 17090072 | 2" & 1" |
| 17090073 | 1 1/2" & 3/4" |
| 17090074 | 1 1/2" & 1" |

- 1) 2" V. INJ / 1 1/2" V. INJ PORT.
- 2) 3/4" V. INJ / 1" V. INJ PORT.
- 3) 2" BY PASS / 1 1/2" BY PASS
- 4) 1" AIRVENT PORT. / 1 1/2" AIRVENT PORT
- 5) BOTH SIDE PRESSURE GAUGE PORT.
- 6) 3" BUTTERFLY VALVE IN MIDDLE.

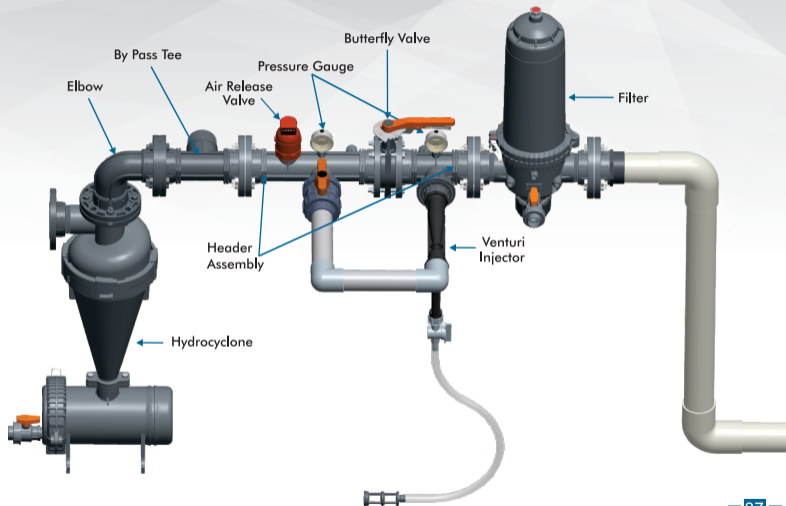

PPGF HEAD UNIT (Flange Threaded)

3"

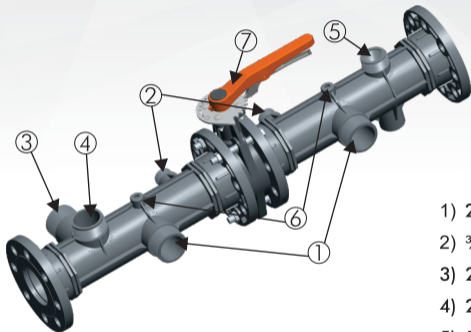

| AIPL Code | Venturi Port |
|-----------|---------------|
| 17090075 | 3/4" & 2" |
| 17090076 | 2" & 1" |
| 17090077 | 1 1/2" & 3/4" |
| 17090078 | 1 1/2" & 1" |

- 1) 2" V. INJ / 1 1/2" V. INJ PORT.
- 2) 3/4" V. INJ / 1" V. INJ PORT
- 3) 2" BY PASS / 1 1/2" BY PASS
- 4) 2" PRV PORT
- 5) 1" & 1 1/2" AIRVENT PORT.
- 6) BOTH SIDE PRESSURE GAUGE PORT.
- 7) 3" BUTTERFLY VALVE IN MIDDLE.

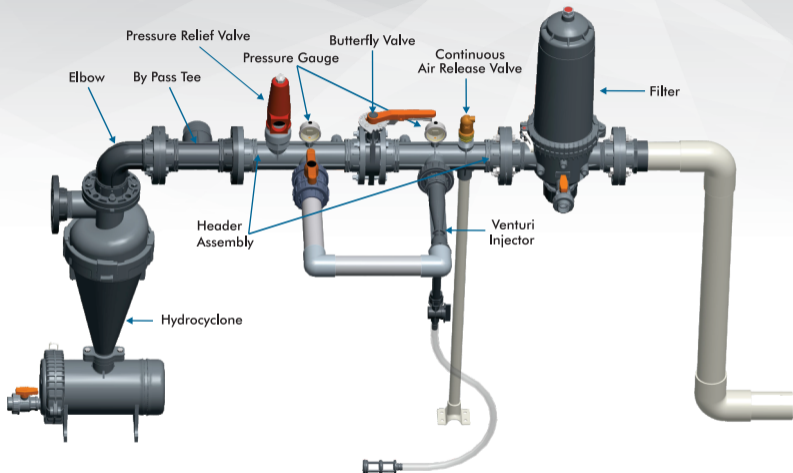

VENTURY (Use Instructions)

$\frac{3}{4}$ " & 1", 1 $\frac{1}{2}$ " & 2"

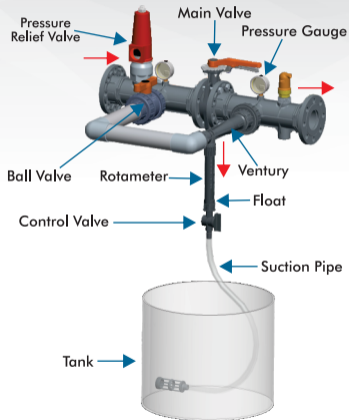
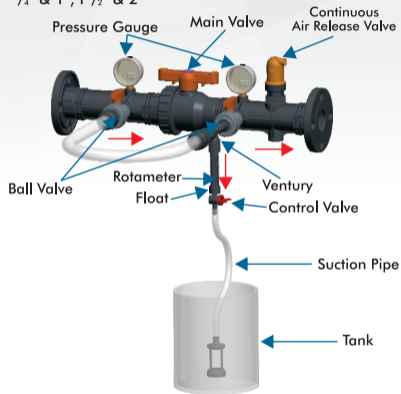

- First of all, place the ventury in the direction of water flow, keeping in mind the position of arrows.
- Completely sink the ventury suction pump into the tank filled with fertilizer.
- Open both the ball valves placed on the ventury. After this, open the control valve attached to the water chaser pipe.
- Meanwhile, observe the pressure gauge placed on the main valve of the head unit.
- Make sure the pressure of both the gauges is same.
- Now gradually start closing the main valve while observing both the pressure gauges.
- While performing this activity, increase in pressure in the first pressure gauge and decrease in the second gauge will be observed.
- Continue closing the main valve until the pressure of both the gauges is differentiated by 0.5 KG. In the absence of pressure gauge, Close the main valve till the time water drags through the suction pipe or float rises up in the Rotameter.
- At the difference of 0.5 KG, ventury will start dragging water.
- After adding fertilizer, open the main valve and close both the ball valves.

FILTERS (Installation)

Screen & Disc

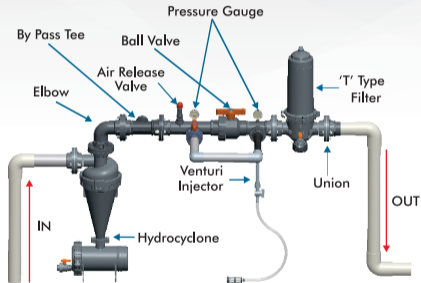
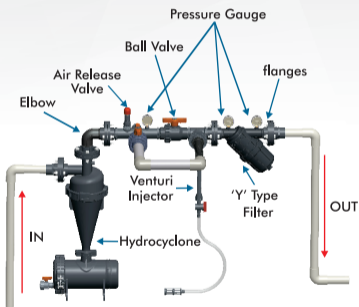

- Install filter vertically in the direction of flow arrow marked on the body.
- Check top filter Cartridge O rings, Body Gasket, Drain Valve O-ring and filter Cartridge for their proper position. (Ref Figure - 4)
- Before installing the manometers, drill the filter in the corresponding threaded seats.
- Never over tighten filter cartridge.
- Flush Filter and clean Filter Cartridge taking it out under water jet tenderly and periodically
- Use diluted chemicals for treatment and water soluble fertilizer with the help of venturi.
- Pouring of concentrated chemicals directly in the filter body will result damage to the screen filter mesh.
- Filter material is resistant to Fertilizers, Nitrates, Sulphates, Phosphates and Urea.
- Safe maximum pressure Drop : 0.5 kg/cm^2

FILTERS (Cleaning)

Screen

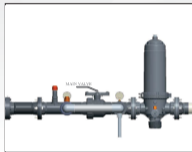

Step 1: Close Main Valve before cleaning process start.

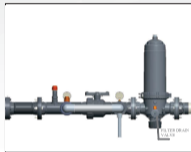

Step 2: Open Filter drain Valve to drain water from Filter. After draining close Drain Valve.

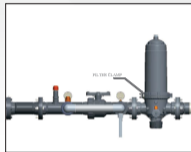

Step 3: Remove clamp by pulling the clamp handle outside, use one hand to unlock the clamp.

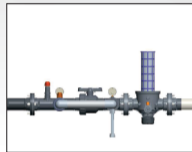

Step 4: After removing the Filter body cap, take out the screen element out of it.

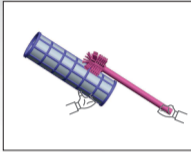

Step 5: Take a plastic brush and softly rub the Screen from outside, during rubbing rinse the water stream. This removes the dirt particles from the screen. Repeat this cleaning process 4-5 times on whole periphery of the screen , until screen element is clean.

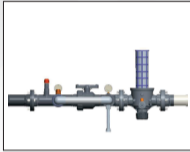

Step 6: Place clean Filter element into body.

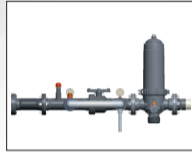

Step 7: Place properly body cap onto Filter and lighten Filter clamp.

FILTERS (Cleaning)

Disc

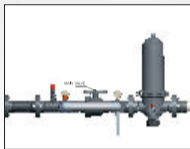

Step 1: Close Main Valve before cleaning process start.

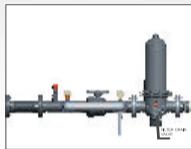

Step 2: Open filter drain valve to drain water from filter. after draining close drain valve.

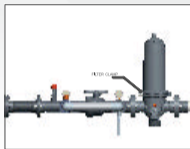

Step 3: Remove the clamp by pulling the clamp handle outside, use one hand to unlock the clamp.



Step 4: After removing the filter body cap, take out the disc filter cartridge out of it.



Step 5: Loosen the disc by unscrewing disc housing scrow, rinse the water jet on disc to separate the dirt particles from the disc surface. Examine the disc to be clean before tighten the disc cartridge.

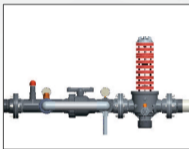

Step 6: Place clean filter element into body.

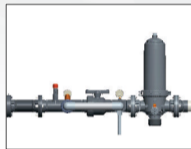

Step 7: Place properly body cap onto filter and tighten filter clamp.



18-19, Dilshad Garden, G T Road, New Delhi-110095. (INDIA)

Tel. : +91-11-43099800-01-02, 22583027, Fax : +91-11-22121035, 43099807

Website : www.automatworld.com : E-mail : contactus@automatworld.com

 <https://www.facebook.com/automatindustries>  <https://twitter.com/automat2014>

 <https://www.youtube.com/automatindustries>